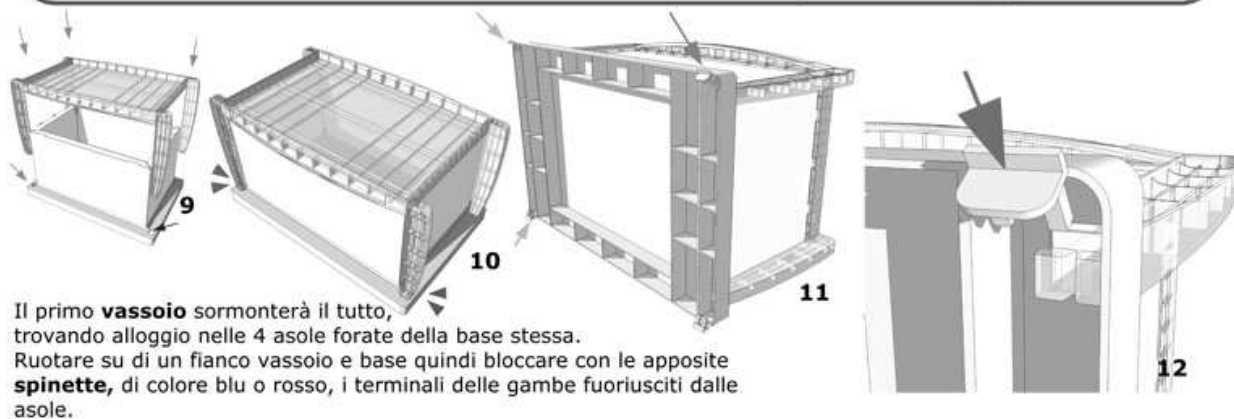
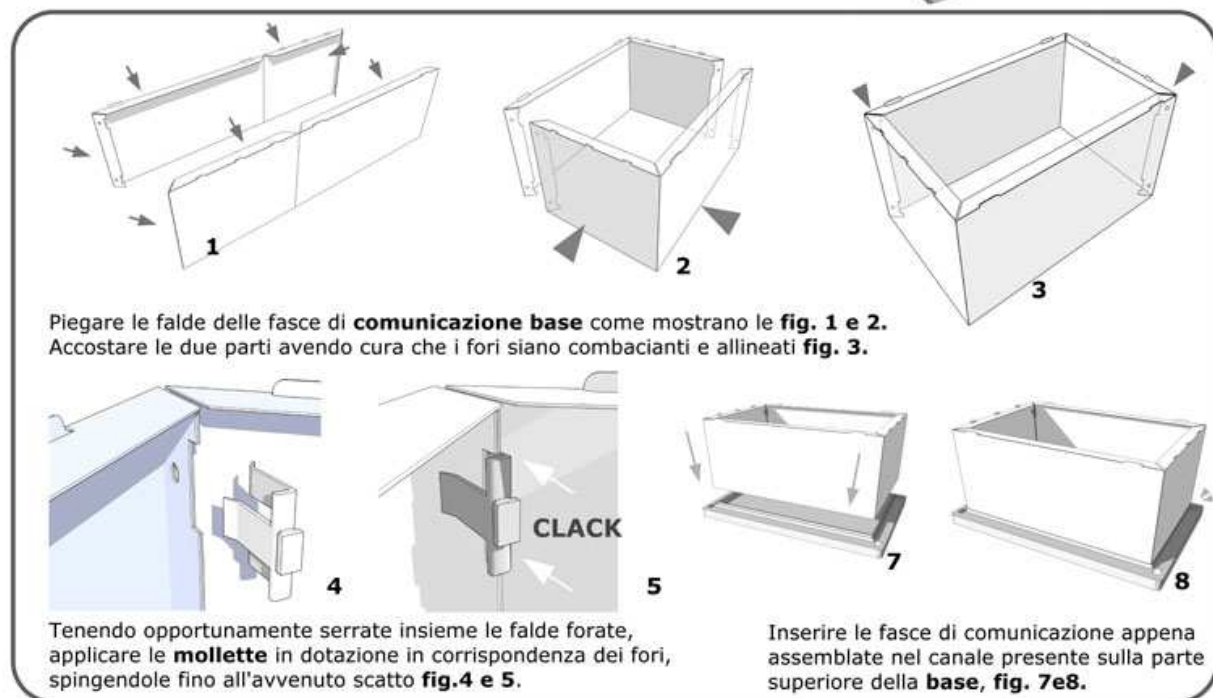
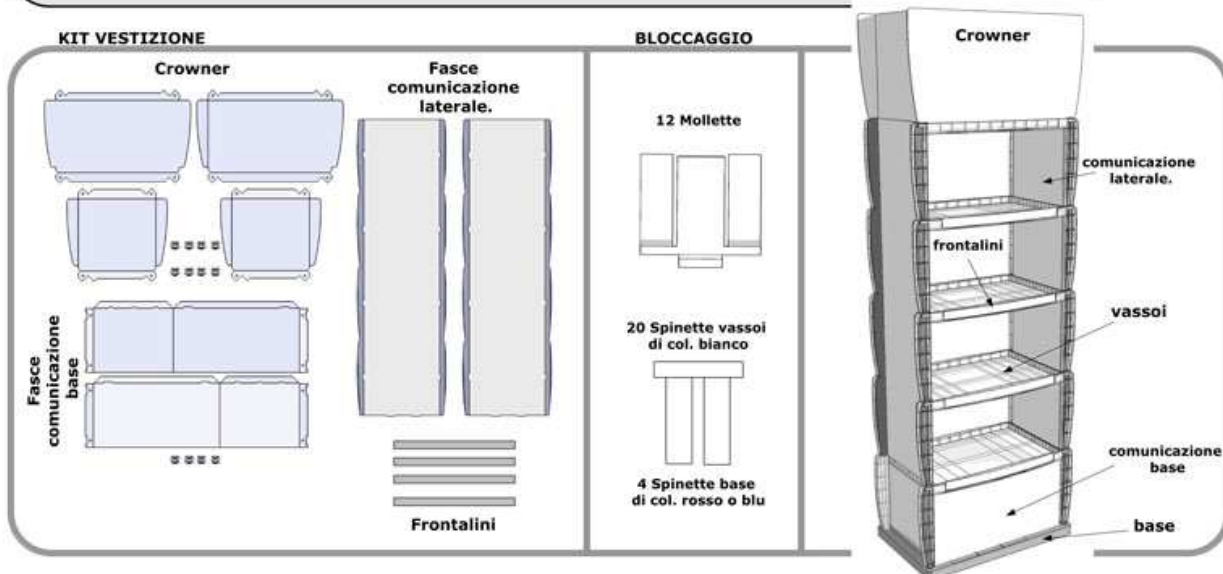
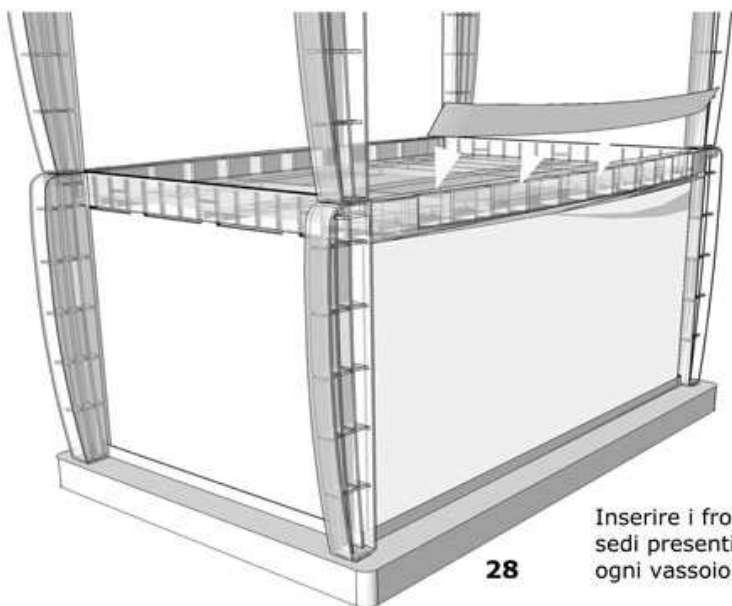

Table istruzioni di montaggio - fianco lungo





28

Inserire i frontalini nelle apposite sedi presenti sul bordo frontale di ogni vassoio.



29

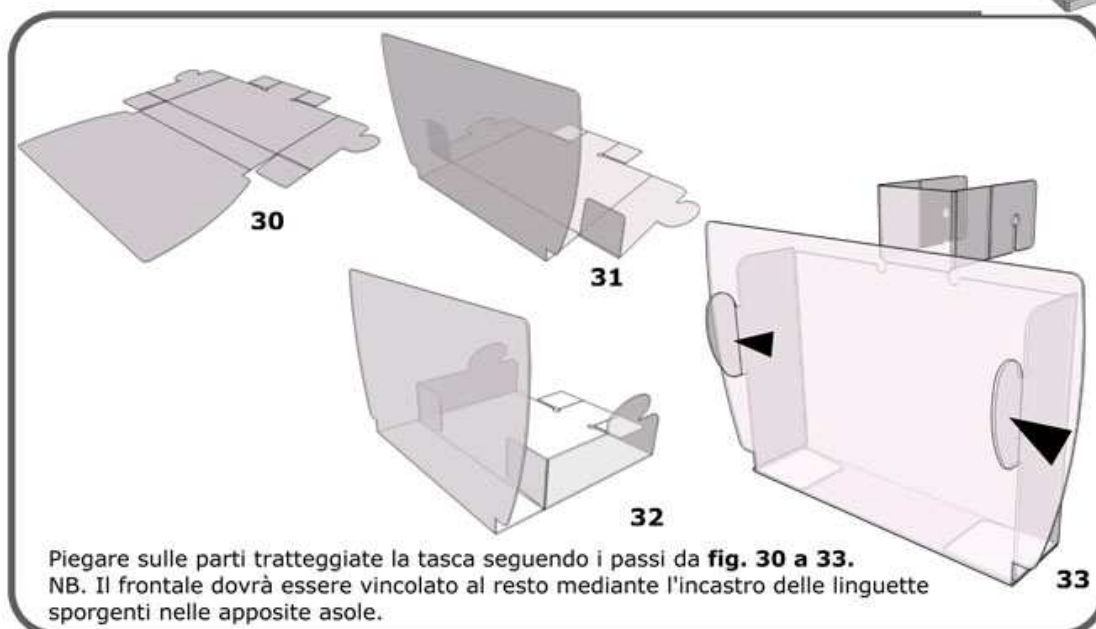

Piegare sulle parti tratteggiate la tasca seguendo i passi da **fig. 30 a 33**.
NB. Il frontale dovrà essere vincolato al resto mediante l'incastro delle linguette sporgenti nelle apposite asole.



34

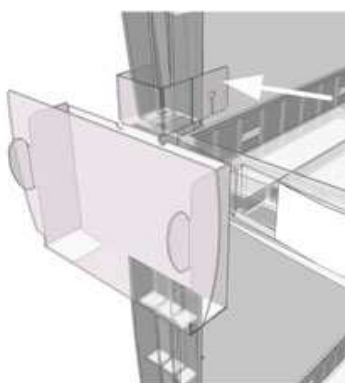

35



36

Fissare la taschina appena assemblata frontalmente al vassoio, sulla parte finale della gamba.
Utilizzare le linguette indicate nelle fig. 35 e 36 opportunamente piegate e incastrate fra di loro.

Il Vostro Display è ultimato

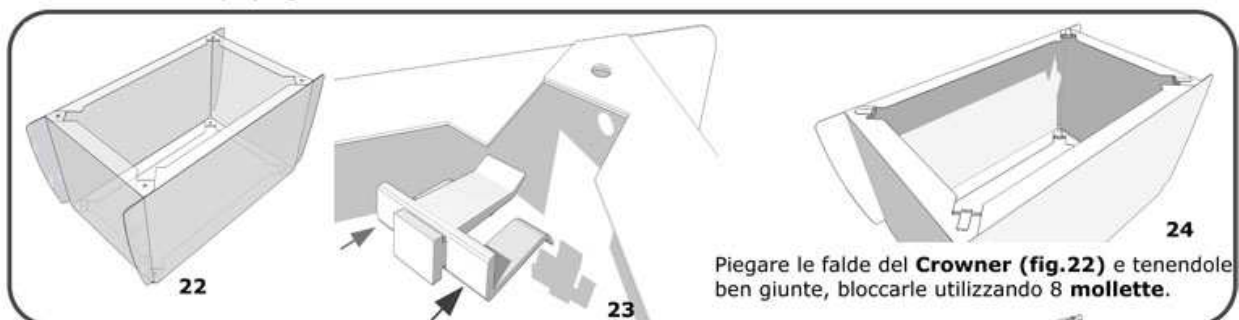
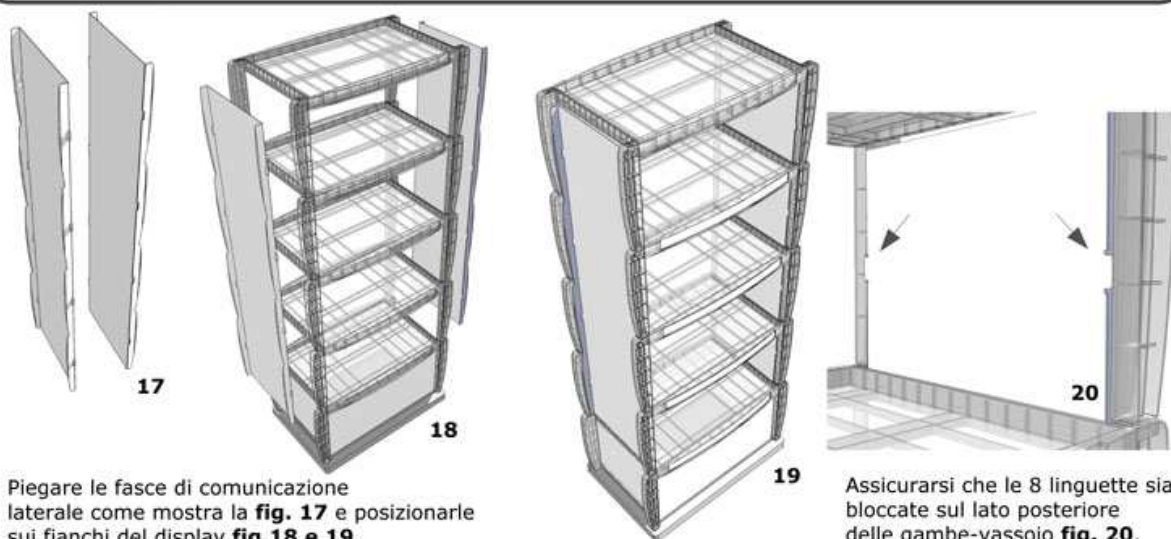

Posizionare il **crown** assemblato **fig.25** sull' ultimo vassoio in alto **fig.26 e 27**.

